



Micro Commercial Components

Micro Commercial Components  
 20736 Marilla Street Chatsworth  
 CA 91311  
 Phone: (818) 701-4933  
 Fax: (818) 701-4939

# SI2302

## Features

- 20V,3.0A,  $R_{DS(ON)}=55m\Omega @V_{GS}=4.5V$   
 $R_{DS(ON)}=82m\Omega @V_{GS}=2.5V$
- High dense cell design for extremely low  $R_{DS(ON)}$
- Rugged and reliable
- Lead free product is acquired
- SOT-23 Package
- Marking Code: S2
- Case Material: Molded Plastic. UL Flammability Classification Rating 94V-0

### Maximum Ratings @ 25°C Unless Otherwise Specified

Symbol	Parameter	Rating	Unit
$V_{DS}$	Drain-source Voltage	20	V
$I_D$	Drain Current-Continuous	3	A
$I_{DM}$	Drain Current-Pulsed <sup>a</sup>	10	A
$V_{GS}$	Gate-source Voltage	$\pm 8$	V
$P_D$	Total Power Dissipation	1.25	W
$R_{\theta JA}$	Thermal Resistance Junction to Ambient <sup>b</sup>	100	$^{\circ}C/W$
$T_J$	Operating Junction Temperature	-55 to +150	$^{\circ}C$
$T_{STG}$	Storage Temperature	-55 to +150	$^{\circ}C$

## N-Channel Enhancement Mode Field Effect Transistor

### SOT-23

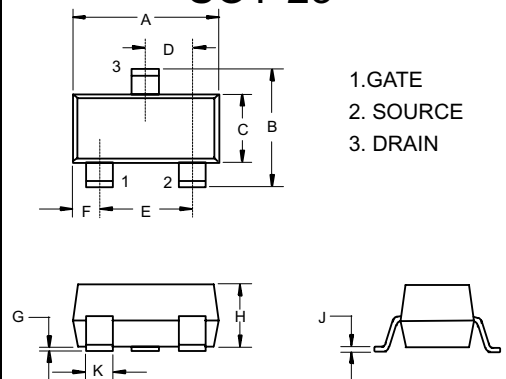

DIM	INCHES		MM		NOTE
	MIN	MAX	MIN	MAX	
A	.110	.120	2.80	3.04	
B	.083	.098	2.10	2.64	
C	.047	.055	1.20	1.40	
D	.035	.041	.89	1.03	
E	.070	.081	1.78	2.05	
F	.018	.024	.45	.60	
G	.0005	.0039	.013	.100	
H	.035	.044	.89	1.12	
J	.003	.007	.085	.180	
K	.015	.020	.37	.51	

## Internal Block Diagram

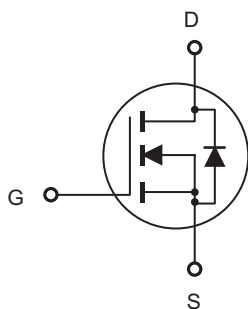

### Suggested Solder Pad Layout

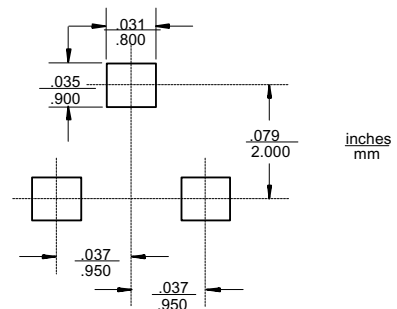



**Electrical Characteristics**  $T_A = 25^\circ\text{C}$  unless otherwise noted

Parameter	Symbol	Test Condition	Min	Typ	Max	Units
<b>Off Characteristics</b>						
Drain-Source Breakdown Voltage	$BV_{DSS}$	$V_{GS} = 0V, I_D = 10\mu A$	20			V
Zero Gate Voltage Drain Current	$I_{DSS}$	$V_{DS} = 20V, V_{GS} = 0V$			1	$\mu A$
Gate Body Leakage Current, Forward	$I_{GSSF}$	$V_{GS} = 8V, V_{DS} = 0V$			100	nA
Gate Body Leakage Current, Reverse	$I_{GSSR}$	$V_{GS} = -8V, V_{DS} = 0V$			-100	nA
<b>On Characteristics</b> <sup>c</sup>						
Gate Threshold Voltage	$V_{GS(th)}$	$V_{GS} = V_{DS}, I_D = 50\mu A$	0.65		1.2	V
Static Drain-Source On-Resistance	$R_{DS(on)}$	$V_{GS} = 4.5V, I_D = 3.6A$		55	72	$m\Omega$
Forward Transconductance		$V_{GS} = 2.5V, I_D = 3.1A$		82	110	$m\Omega$
	$g_{FS}$	$V_{DS} = 5V, I_D = 3.6A$		8.5		S
<b>Dynamic Characteristics</b> <sup>d</sup>						
Input Capacitance	$C_{iss}$	$V_{DS} = 10V, V_{GS} = 0V, f = 1.0\text{ MHz}$		237		pF
Output Capacitance	$C_{oss}$			120		pF
Reverse Transfer Capacitance	$C_{rss}$			45		pF
<b>Switching Characteristics</b> <sup>d</sup>						
Turn-On Delay Time	$t_{d(on)}$	$V_{DD} = 10V, I_D = 3.6A, V_{GS} = 4.5V, R_{GEN} = 6\Omega$		23	45	ns
Turn-On Rise Time	$t_r$			11	30	ns
Turn-Off Delay Time	$t_{d(off)}$			34	70	ns
Turn-On Fall Time	$t_f$			36	70	ns
Total Gate Charge	$Q_g$	$V_{DS} = 10V, I_D = 3.6A, V_{GS} = 4.5V$		6	10	nC
Gate-Source Charge	$Q_{gs}$			1.4		nC
Gate-Drain Charge	$Q_{gd}$			1.8		nC
<b>Drain-Source Diode Characteristics and Maximum Ratings</b>						
Drain-Source Diode Forward Current <sup>b</sup>	$I_S$				0.94	A
Drain-Source Diode Forward Voltage <sup>c</sup>	$V_{SD}$	$V_{GS} = 0V, I_S = 0.94A$			1.2	V
<b>Notes :</b> a.Repetitive Rating : Pulse width limited by maximum junction temperature. b.Surface Mounted on FR4 Board, $t \leq 10$ sec. c.Pulse Test : Pulse Width $\leq 300\mu s$ , Duty Cycle $\leq 2\%$ . d.Guaranteed by design, not subject to production testing.						

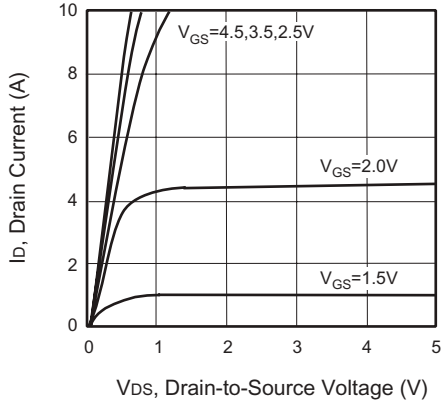

Figure 1. Output Characteristics

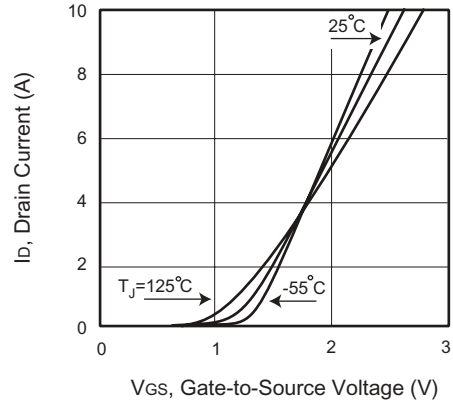

Figure 2. Transfer Characteristics

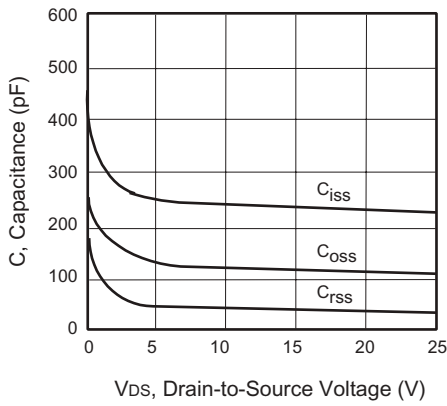

Figure 3. Capacitance

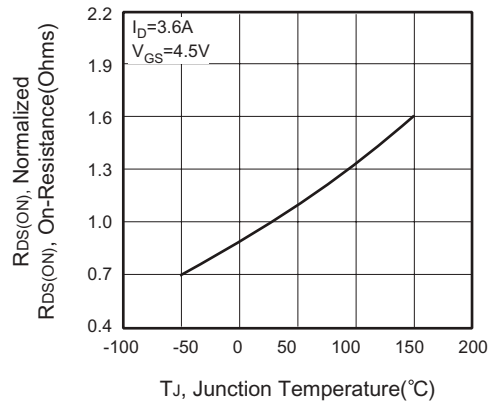

Figure 4. On-Resistance Variation with Temperature

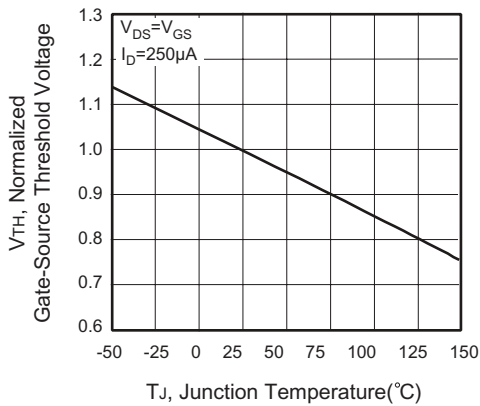

Figure 5. Gate Threshold Variation with Temperature

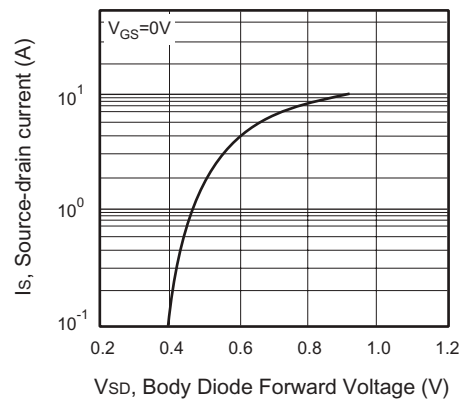

Figure 6. Body Diode Forward Voltage Variation with Source Current

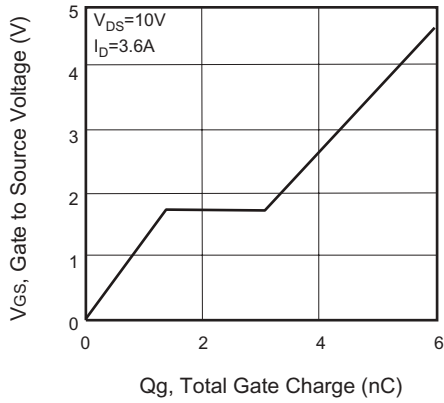

Figure 7. Gate Charge

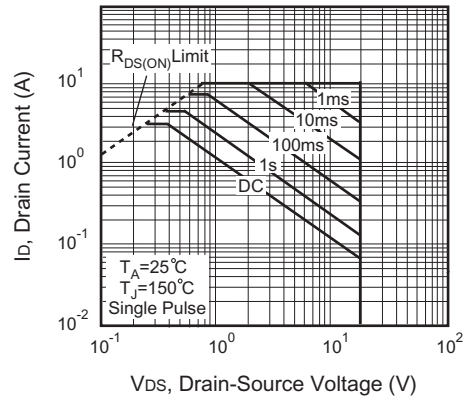

Figure 8. Maximum Safe Operating Area

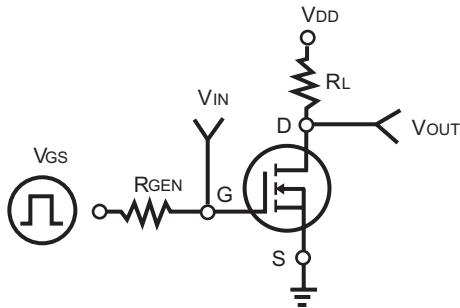

Figure 9. Switching Test Circuit

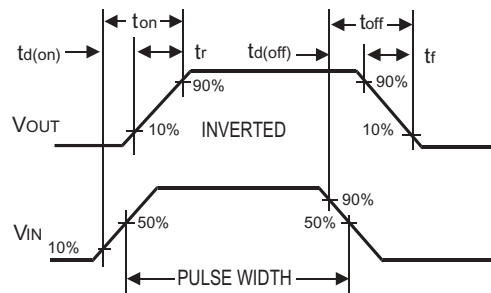

Figure 10. Switching Waveforms

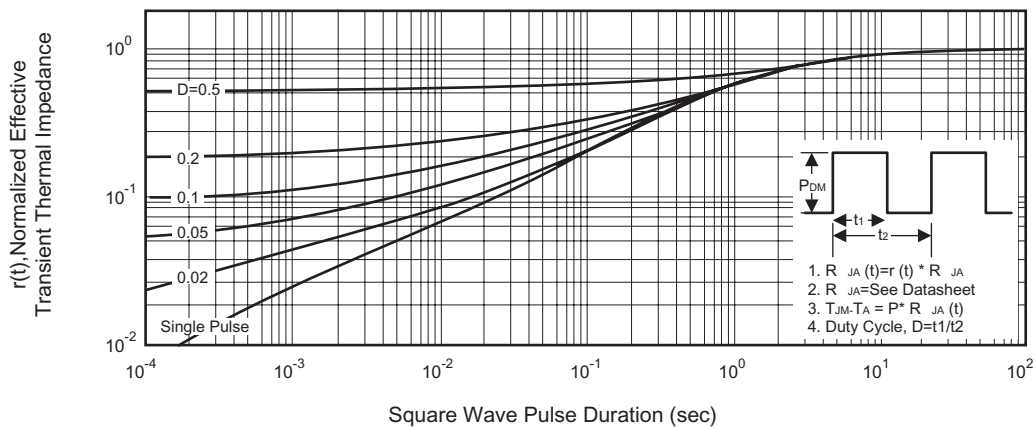

Figure 11. Normalized Thermal Transient Impedance Curve



Micro Commercial Components

## Ordering Information

Device	Packing
(Part Number)-TP	Tape&Reel;3Kpcs/Reel

**\*\*\*IMPORTANT NOTICE\*\*\***

*Micro Commercial Components Corp.* reserves the right to make changes without further notice to any product herein to make corrections, modifications, enhancements, improvements, or other changes. *Micro Commercial Components Corp.* does not assume any liability arising out of the application or use of any product described herein; neither does it convey any license under its patent rights, nor the rights of others. The user of products in such applications shall assume all risks of such use and will agree to hold *Micro Commercial Components Corp.* and all the companies whose products are represented on our website, harmless against all damages.

**\*\*\*APPLICATIONS DISCLAIMER\*\*\***

Products offer by *Micro Commercial Components Corp.* are not intended for use in Medical, Aerospace or Military Applications.